

MODEL 500 TEKNİK ÖZELLİKLERİ

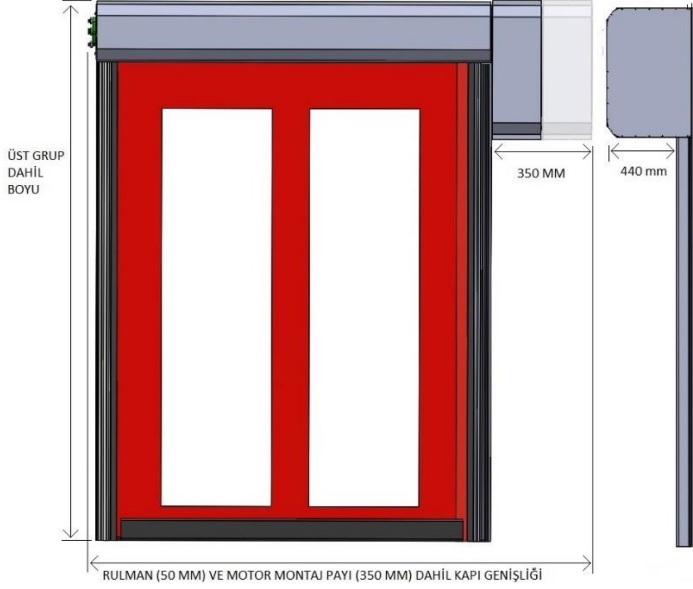

AÇIKLAMA

MODE L 500 KAPILAR BİLGİSİZ İÇ MEKAN UYGULAMALARINDA TERCİH EDİLEN VE ÇARPMA-DARBE SONRASINDA KENDİNİ TAMİR EDEBİLEN YAPIDADIR.

YÜKSEK SIZDIRMAZLIĞI İLE TOZ VE HAVA SİRKÜLYASYONUNU MİNİMUMA İNDİRİR. SESSİZ VE KULLANIŞLIDIR.

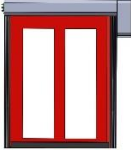

KAPI ÖLÇÜLERİ

ÜST GRUP DAHİL TOPLANMA PAYI MAX 650 MM

MAX YÜKSEKLİK 4000 MM

DİKME DERİNLİĞİ 80 mm

MAX GENİŞLİK 3000 MM

DİKME GENİŞLİĞİ 100 mm



BRANDA ÖZELLİKLERİ

900 GR M2 2200 DENYE ALEVYÜRÜMEZ BRANDA (ANTİSTATİK ÖZELLİKLİ) BAZA

LASTİK ALT

2 MM PVC ŞEFFAF CAM

ENDÜSTRİYEL TİP İTHAL FERMUAR

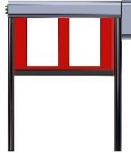

ACİL AÇMA

MOTOR ARKASI MANUEL KOL



KAPI HIZI

STANDART 0,70 MT/SN

SÜRÜCÜLÜ 1,20 MT/SN



RÜZGAR DAYANIMI

50 KM/H



METAL AKSAM

DİKMELER VE KAPAKLAR ELOKSAL ALÜMİNYUM

PLASTİK DİKME KANALALRI



OTOMASYON

380 VAC 0,75 KW ~ 2,2 KW MOTOR

PLC GÖSTERGELİ EKLAN

İ15 - 50 GÖVDE REDİKTÖR

REFLEKTE TİP EMNİYET FOTOSELİ

110 VDC - 200 VDC ELEKTROMANYETİK FREN

KARŞI EKSTRA BUTON

KAYIŞ AKTARMALI KAM KONTROLLÜ SIVIÇ

KAPAĞA MONTE FLAŞÖRLÜ SİREN

220 VEYA 380 KONTROL PANOSU

TÜM HARİCİ AÇMA KAPAMA SİSTEMLERİNE UYGUNDUR

ORSEZ MODEL 500 KURULUM

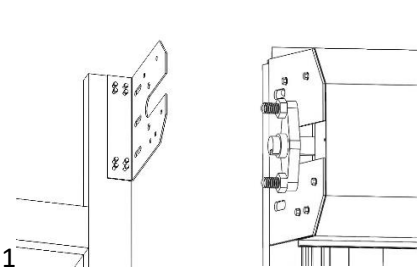

1
Plakayı alt sıfırına dikme, iç kısmının sıfırına üst kapak sığacak mesafede takın.

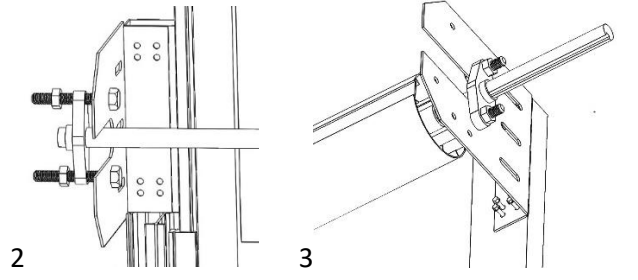

2
Tamburu ve rulmanlarını takın.

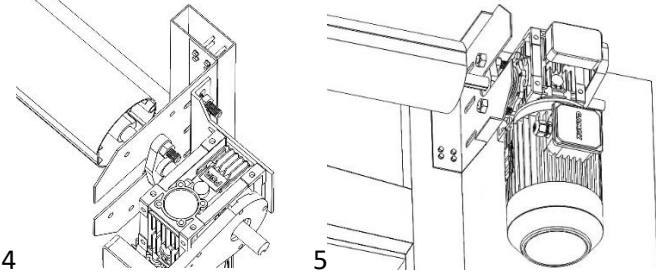

4
Motoru mile geçirip plakasını bağlayın.

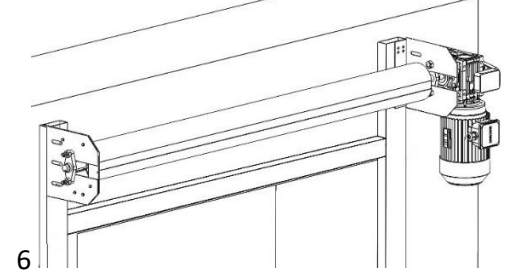

6
Üst grup bittiğinde bu şekilde gözükecektir.

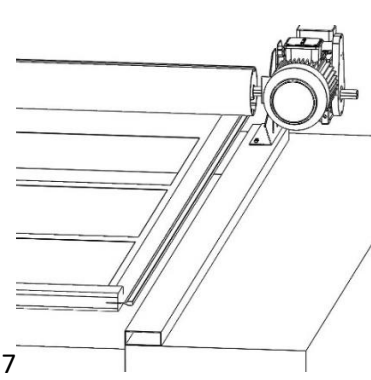

7
Brandayı yer seviyesine kadar indirin.

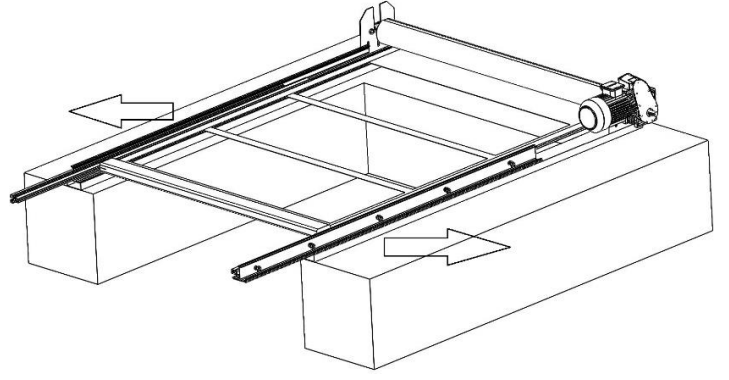

8
Sağ ve sol dikmeleri fermuarlara geçirin. Yanlara doğru gerdirerek gönyesinde duvara monte edin.

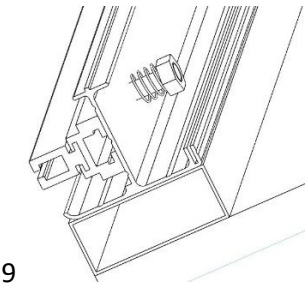

9
Dikmelerin kapağı takılıp montajlanmış şekilleri.

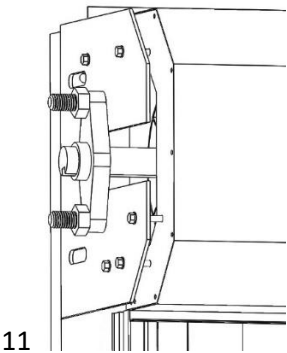
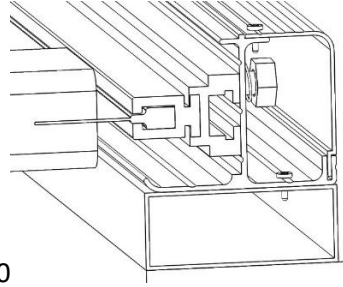

11

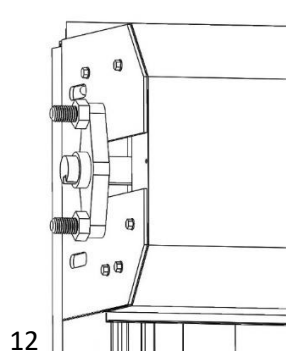

12

Son olarak üst kapağı iki bayrak arasına sıfır oturacak şekilde monte edin. Üst kapak ile bayraklar arasında boşluk kalıyorsa hatalı montaj yapılmış demektir.